

# Users Manual

## G-Wiz LC ARLISS

### 1.0 Overview

The G-Wiz LC ARLISS is a precision, state-of-the-art Flight Computer for model and high power rocketry. The G-Wiz LC is a low-cost, feature-packed computer comprised of an accelerometer, high performance RISC processor, and 2 high current pyrotechnic driver channels. The G-Wiz LC ARLISS has all of the features of the LC plus a third high current pyrotechnic driver channel.

G-Wiz Flight Computers use proprietary firmware algorithms to determine the key events in a rocket's trajectory. The key events monitored are:

- launch
- booster burn-out
- sustainer ignition (when applicable)
- sustainer burn-out (when applicable)
- coast,
- apogee

Peak inertial altitude is flashed out, on the Status LED, at the end of flight.

### 2.0 Specifications

Parameter	G-Wiz LC ARLISS
Max. Acceleration	+/- 50 g
Max. Barometric Altitude	-
Number of Pyro channels	3
Maximum current per Pyro channel	8 Amps
Number of batteries required	1 or 2
Recommended Battery	9 VDC transistor battery (Duracell MN1604)
Max. voltage applied to Flight Computer (terminal block pins 7 & 8)	15 VDC
Computer current consumption	16mA typ.
Max. Pyro channel voltage	60 VDC
Pyro channel test current (9VDC battery)	3.5mA
Pyro channel firing time	1 second
Pyro channel functions	<b>1:</b> Apogee parachute deployment, <b>2:</b> Post apogee delay 1 (4/6 seconds) <b>3:</b> Post apogee delay 2 (8/12 seconds)
Low Altitude Pyro channel activation	-
Altitude readout	Flashing LED (Status LED) Inertial Altitude
Number of LEDs	1 Status LED 3 Pyro Continuity LEDs
Main Battery Life (with separate Pyro Battery)	25 hours
Operating Temp. Range	0-70°C

### 3.0 Post Apogee Timer 1 / 2 Configuration

Pin plug jumper, JP2, controls the delay times for Post Apogee Timers 1 and 2. The following table defines the time delay configurations. When JP2 is installed, the Status LED will repeatedly blink twice in succession followed by a delay. When JP2 is removed, the Status LED will only blink once.

JP2 Jumper -In/Out	Post Apogee Timer 1 (Pyro 2)	Post Apogee Timer 2 (Pyro 3)
Out	4 seconds	8 seconds
In (default)	6 seconds	12 seconds

### 4.0 JP1 Terminal Block Wiring

Terminal block, JP1, allows the user to quickly connect the leads from Pyro charges to the G-Wiz LC ARLISS Flight Computer. The two wires from a pyro charge or squib are connected between a Pyro Channel's '+' and '-' terminals on the JP1 terminal block. Care should be exercised when connecting the battery leads to the terminal block to avoid polarity reversals. The computer is protected from polarity reversals. **CAUTION: IF YOU REVERSE THE POLARITY OF THE PYRO BATTERY, ANY SQUIBS OR PYRO CHARGES CONNECTED TO G-WIZ'S PYRO CHANNELS WILL FIRE IMMEDIATELY!!!**

The factory-installed jumper from JP1 pin 5 to JP1 pin 7 (terminal block) supplies power to the flight computer, under normal operation. When using the high current configuration, this jumper must be removed. You **must** use two separate batteries when using the high current configuration. This prevents power to the computer from being contaminated by glitches in the pyro power. When using the high current configuration, the jumper from JP1 pin 5 to pin 7 **must** be removed. Failure to remove this jumper, when using the high current configuration, can result in damage the LC/LC Deluxe Flight Computer and void the warranty.

All of the Pyro channel outputs are open drain outputs. Terminal block pins 1, 3, and 5 are common and connect directly to the pyro battery. They are provided to ease the wiring of Pyro charges to the Flight Computer. The "-" (minus) side of each Pyro channel is connected to the drain of a high current, n-channel, power MOSFET (open drain output).

JP1- # (Terminal Block)	Function
1	Pyro Channel 1 (+)
2	Pyro Channel 1 (-)
3	Pyro Channel 2 (+)
4	Pyro Channel 2 (-)
5	Pyro Channel 3 (+)
6	Pyro Channel 3 (-)
7	Main Battery (+) <i>red wire</i>
8	Main Battery (-) <i>black wire</i>

### 5.0 Pyro Channels, Continuity LEDs, and Pyro Battery

Each of the 3 Pyro channels has a corresponding continuity LED. The Pyro Continuity LEDs will flash in unison with the Status LED. Each channel will fire for 1 second corresponding to the flight event detected (apogee, post-apogee timer 1, post-apogee timer 2).

When using low current electric matches, such as DaveyFire™, a single 9 VDC transistor battery will be adequate to supply current to the electric match and flight computer. If using high current igniters, like FireStar™ and IgniterMan™, you **must** use separate batteries for computer power and pyro power. To 'split' the pyro and computer power, remove the factory-installed jumper between JP1 pin 5 and JP1 pin 7 (terminal block). The soldered-in battery wires now provide power to the pyro channels ONLY. The user must wire a second battery harness to the terminal block, JP1 pin 7 (+) and JP1 pin 8 (-). This can be a separate 9 VDC transistor battery or series connected AA cells producing a voltage of 12 VDC, depending on the voltage/current requirements. The following schematic will help clarify wiring. We strongly recommend using only fresh high quality batteries, for best results. **CAUTION: IF YOU REVERSE THE POLARITY OF THE PYRO BATTERY, ANY SQUIBS OR PYRO CHARGES CONNECTED TO G-WIZ'S PYRO CHANNELS WILL FIRE IMMEDIATELY!!!**

**NOTE: We strongly urge rocketeers to use the DUAL battery configuration when firing igniters or electric matches. These devices have peak current demands that exceed the capability of 9 VDC transistor batteries. Failure to use the dual battery configuration, when firing igniters or electric matches may ultimately result in a catastrophic flight failure. This failure is due to the momentary loss of power to the computer circuitry (just like a momentary AC power brown-out may cause a computer to crash or reset).**

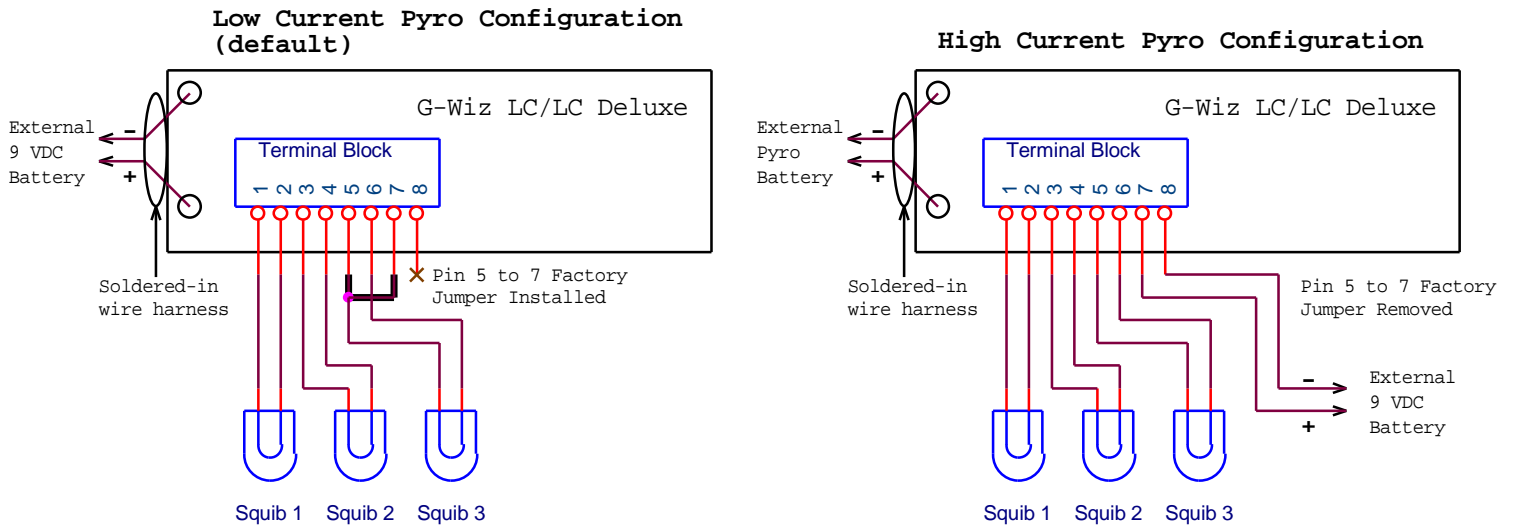

Users with high current Pyro channel requirements should consult Motorola's datasheet for the MTD3055VL device. This is the device used on LC and LC Deluxe. Contact G-Wiz Partners if you have higher current needs.

Pyro Channel #	Fires on Flight Event
1	Apogee (minimum velocity)
2	Post Apogee Timer 1
3	Post Apogee Timer 2

## 6.0 Status LED and Altitude readout

Altitude is flashed out on the Status LED. Prior to launch, the Status LED flashes the operational mode, cluster or stage. Upon launch detect, the Status LED remains extinguished during flight until Post Apogee Timer 2 fires. G-Wiz LC ARLISS will commence altitude readout, on the Status LED, after Post Apogee Timer 2 fires. Digits are flashed out, in order, from most significant to least significant digit. The number of flashes represents the digit (e.g. the number '7' is represented by 7 flashes of the Status LED). A zero is one long 'on' period. There is a 2-second delay with the Status LED extinguished before the sequence repeats.

## 7.0 G-Wiz Mechanical

G-Wiz is designed to be mounted using #4 hardware. There are two mounting holes provided. When mounting G-Wiz in your rocket, be certain to orient the terminal block side of G-Wiz toward the aft or motor side of the rocket. G-Wiz will **not** operate unless oriented in the correct direction (see figure below).

**When installing G-Wiz LC or LC Deluxe into a rocket, it must be protected from the ejection gases produced by the Pyro charges. The gases are corrosive, will damage the Flight Computer, and void your warranty.** Install the Flight Computer in a separate compartment that is gas tight from the ejection gases.

The drawing below shows the key mechanical dimension and mounting orientation. All dimensions listed are in inches.

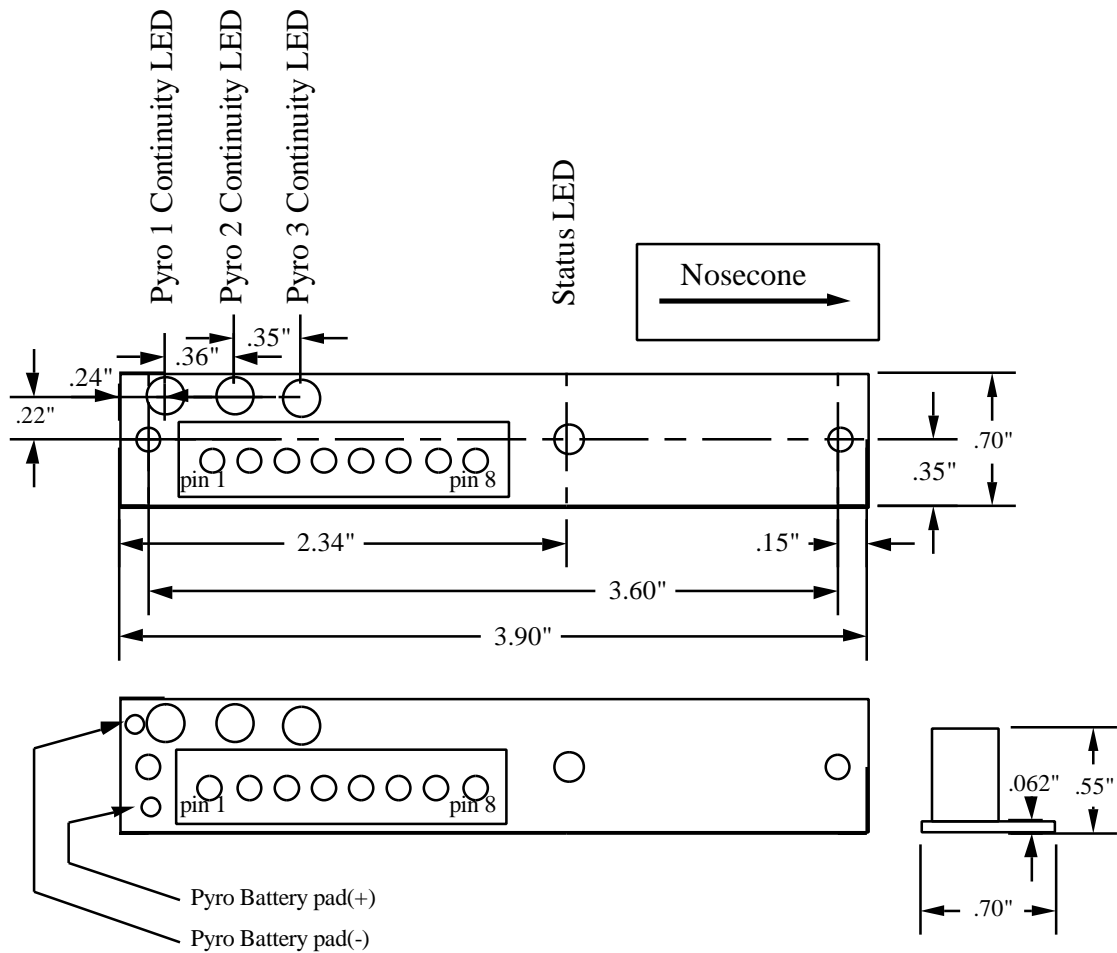

## 8.0 Limited Warranty and Disclaimer

G-Wiz Partners warrants the G-Wiz LC or LC Deluxe Flight Computer to be free from defects in materials and workmanship and remain in working order for a period of 180 days. If the unit fails to operate as specified, the unit will be repaired or replaced at the discretion of G-Wiz Partners, provided the unit has not been damaged, modified, or serviced by anyone except for the manufacturer.

G-Wiz LC and LC Deluxe Flight Computers are sold as an experimental accessory only. Due to the nature of experimental electronic devices, especially when used in experimental carriers such as rockets, the possibility of failure can never be totally removed. The owners, employees, vendors and contractors of G-Wiz Partners shall not be liable for any special, incidental, or consequential damage or expense directly or indirectly arising from the customer or anyone's use, misuse, or inability to use this device either separately or in combination with other equipment or for personal injury or loss or destruction of other property, for experiment failure, or for any other cause. It is up to the user, the experimenter, to use good judgment and safe design practices and to properly pre-test the device for its intended performance in the intended vehicle. It is the user or experimenter's responsibility to assure the vehicle will perform in a safe manner and that all reasonable precautions are exercised to prevent injury or damage to anyone or anything. **WARNING:** Do not use this device unless you completely understand and agree with all the above statements and conditions. First time use of the G-Wiz LC or LC Deluxe Flight Computer signifies the user's acceptance of these terms and conditions.